

ITEM TECHNICAL CARD

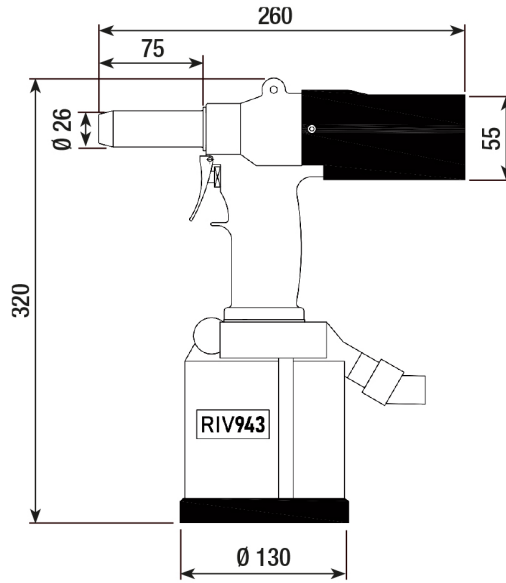

consommation d'air par cycle 6 bar (lt)	7,5
course (mm)	10,0
pression de travail d'air (bar)	6,0
pression d'air min.-max. (bar)	5/7
poids (kg)	3,1
niveau sonore dB(A)	< 90,0
vibrations (m/s ²)	< 2,5
force (N)	32.000
la vitesse du moteur tourne (rpm)	2100
la vitesse du moteur dévissage (rpm)	2500

DESCRIZIONE \ DESCRIPTION: RIV943-Hydrop. tool for inserts in box w/out kit M4-M12			CATEGORIA \ CATEGORY: 6568800	
MATERIAL \ MATERIAL:		TRATTAMENTO TERMICO \ HEAT TREATMENT:		NOTE \ NOTES:
ESEGUITO DA \ DRAWN BY: RIVIT	DATA:	TRATT. SUPERFICIALE \ SURF. TREATMENT:	Rugosità superficiale generale: General surface roughness:	
CONTROLLATO DA \ CHECKED BY: RIVIT	DATA:	PROFONDITÀ TRATTAMENTO TERMICO (SURF) [mm]: HEAT TREATMENT (SURF) DEPTH [mm]:	NON SCALARE IL DISEGNO DO NOT RESIZE THE DRAW	
APPROVATO DA \ APPROVED BY: RIVIT	DATA:	DUREZZA \ HARDNESS:	FOGLIO \ SHEET: 1 OF 1	FORMATO FOGLIO: SHEET FORMAT: A4
		PESO \ WEIGHT:	Scale \ SCALE:	CARTIGLIO \ FORMAT Mod.P023_07
			FASTENERS & TOOLS RIVIT.IT	