

ITEM TECHNICAL CARD

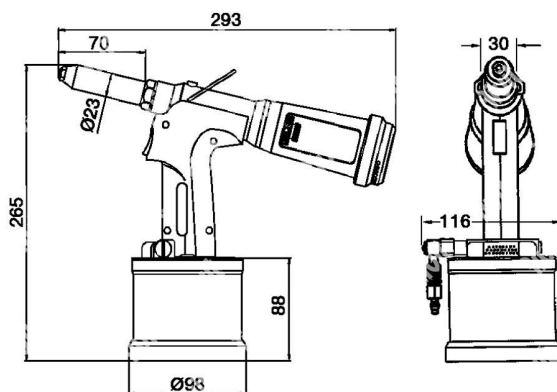

consommation d'air par cycle 6 bar (lt)	2,6
course (mm)	20
force de traction à 6bar (N)	8500
pression de travail d'air (bar)	5
pression d'air min.-max. (bar)	3/7
poids (kg)	1,429
niveau sonore dB(A)	77,5
vibrations (m/s ²)	< 2,5

DESCRIZIONE \ DESCRIPTION: RIV502-Hydropneumatic tool for rivets up to d.4,0 (all materials) and		CATEGORIA \ CATEGORY: 4102900	
MATERIAL \ MATERIAL:		TRATTAMENTO TERMICO \ HEAT TREATMENT:	NOTE \ NOTES:
ESEGUITO DA \ DRAWN BY: RIVIT	DATA:	TRATT. SUPERFICIALE \ SURF. TREATMENT:	Rugosità superficiale generale: General surface roughness:
CONTROLLATO DA \ CHECKED BY: RIVIT	DATA:	PROFONDITÀ TRATTAMENTO TERMICO (SURF) [mm]: HEAT TREATMENT (SURF) DEPTH [mm]:	NON SCALARE IL DISEGNO DO NOT RESIZE THE DRAW
APPROVATO DA \ APPROVED BY: RIVIT	DATA:	DUREZZA \ HARDNESS:	METODO 1 (ISO 128) REVISIONE: METHOD 1 (ISO 128) REVISION:
		PESO \ WEIGHT:	CARTIGLIO \ FORMAT Mod.P023_07
		FOGLIO \ SHEET: 1 OF 1	FORMATO FOGLIO: SHEET FORMAT: A4
		Scale \ SCALE:	



**FASTENERS
& TOOLS**
RIVIT.IT