

ITEM TECHNICAL CARD

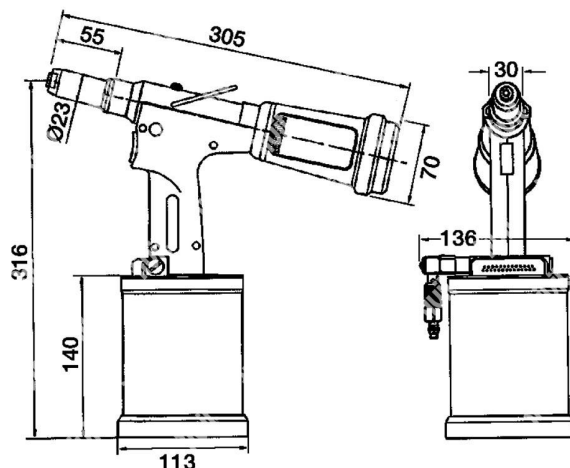

consommation d'air par cycle 6 bar (lt)	4,8
course (mm)	26
force de traction à 6bar (N)	16000
pression de travail d'air (bar)	6
pression d'air min.-max. (bar)	5 - 7
poids (kg)	1,866
niveau sonore dB(A)	78,5
vibrations (m/s ²)	< 2,5

DESCRIZIONE \ DESCRIPTION: RIV504-Hydropneumatic tool for rivets up to d.6,4 (all materials) and		CATEGORIA \ CATEGORY: 4035800	
MATERIAL \ MATERIAL:		TRATTAMENTO TERMICO \ HEAT TREATMENT:	
ESEGUITO DA \ DRAWN BY: RIVIT	DATA:	TRATT. SUPERFICIALE \ SURF. TREATMENT:	Rugosità superficiale generale: General surface roughness:
CONTROLLATO DA \ CHECKED BY: RIVIT	DATA:	PROFONDITÀ TRATTAMENTO TERMICO (SURF) [mm]: HEAT TREATMENT (SURF) DEPTH [mm]:	NON SCALARE IL DISEGNO DO NOT RESIZE THE DRAW
APPROVATO DA \ APPROVED BY: RIVIT	DATA:	DUREZZA \ HARDNESS:	FUOGIO \ SHEET: 1 OF 1
		PESO \ WEIGHT:	FORMATO FOGGIO: A4
		Scale \ SCALE:	CARTIGLIO \ FORMAT Mod.P023_07
			METODO 1 (ISO 128) REVISIONE: METHOD 1 (ISO 128) REVISION:



FASTENERS & TOOLS
RIVIT.IT