

ITEM TECHNICAL CARD

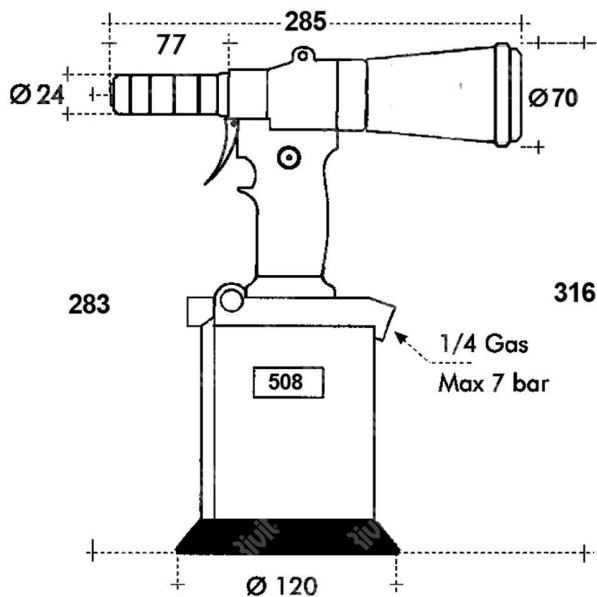

consommation d'air par cycle 6 bar (lt)	4,9
course (mm)	21
force de traction à 6bar (N)	21000
pression de travail d'air (bar)	6
pression d'air min.-max. (bar)	5 - 7
niveau sonore dB(A)	78,5
vibrations (m/s <sup>2</sup> )	< 2,5
poids sans kit (kg)	2,350

DESCRIZIONE \ DESCRIPTION: <b>RIV508-Hydropneumatic tool in case without kit (kit to be ordered)</b>		CATEGORIA \ CATEGORY: <b>3008000</b>	
MATERIAL \ MATERIAL:		TRATTAMENTO TERMICO \ HEAT TREATMENT:	
ESEGUITO DA \ DRAWN BY: <b>RIVIT</b>	DATA:	TRATT. SUPERFICIALE \ SURF. TREATMENT:	Rugosità superficiale generale: General surface roughness:
CONTROLLATO DA \ CHECKED BY: <b>RIVIT</b>	DATA:	PROFONDITÀ TRATTAMENTO TERMICO (SURF) [mm]: HEAT TREATMENT (SURF) DEPTH [mm]:	<b>NON SCALARE IL DISEGNO DO NOT RESIZE THE DRAW</b>
APPROVATO DA \ APPROVED BY: <b>RIVIT</b>	DATA:	DUREZZA \ HARDNESS:	METODO 1 (ISO 128) METHOD 1 (ISO 128)
		PESO \ WEIGHT:	REVISIONE: REVISION:
		FOGLIO \ SHEET: <b>1 OF 1</b>	CARTIGLIO \ FORMAT <b>Mod.P023_07</b>
		FORMATO FOGLIO: SHEET FORMAT: <b>A4</b>	



**FASTENERS  
& TOOLS**  
RIVIT.IT