

ITEM TECHNICAL CARD

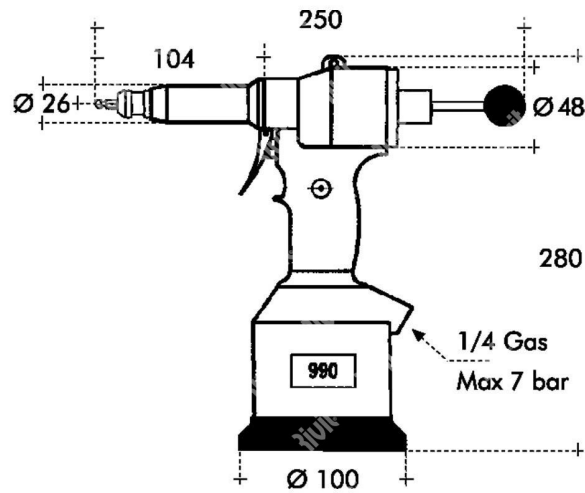

consommation d'air par cycle 6 bar (lt)	2,5
course (mm)	6
force de traction à 6bar (N)	19000
pression de travail d'air (bar)	6
pression d'air min.-max. (bar)	5 - 7
niveau sonore dB(A)	< 80
vibrations (m/s ²)	< 2,5
poids sans kit (kg)	2,133

DESCRIZIONE \ DESCRIPTION: RIV990- Hydrop. hexcutter tool in a box without ki (kit on request				CATEGORIA \ CATEGORY: 2986300	
MATERIAL \ MATERIAL:		TRATTAMENTO TERMICO \ HEAT TREATMENT:		NOTE \ NOTES:	
ESEGUITO DA \ DRAWN BY: RIVIT	DATA:	TRATT. SUPERFICIALE \ SURF. TREATMENT:	Rugosità superficiale generale: General surface roughness:		
CONTROLLATO DA \ CHECKED BY: RIVIT	DATA:	PROFONDITÀ TRATTAMENTO TERMICO (SURF) [mm]: HEAT TREATMENT (SURF) DEPTH [mm]:	NON SCALARE IL DISEGNO DO NOT RESIZE THE DRAW		
APPROVATO DA \ APPROVED BY: RIVIT	DATA:	DUREZZA \ HARDNESS:	FOGLIO \ SHEET: 1 OF 1	FORMATO FOGLIO: SHEET FORMAT: A4	METODO 1 (ISO 128) METHOD 1 (ISO 128) REVISIONE: REVISION:
		PESO \ WEIGHT:	Scale \ SCALE:	CARTIGLIO \ FORMAT Mod.P023_07	



**FASTENERS
& TOOLS**
RIVIT.IT