

ITEM TECHNICAL CARD

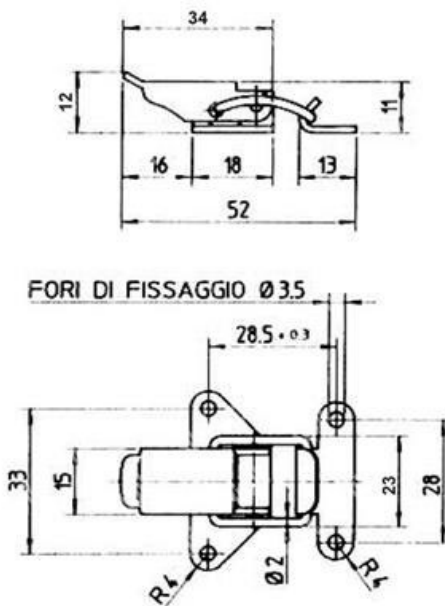

charge de travail max (N)	550
tension de charge max (N)	1500
matière et finition	galvanisé blanc

DESCRIZIONE \ DESCRIPTION: Grenouillère a/crochet GB 2.04.00.04		CATEGORIA \ CATEGORY: 2397700	
MATERIAL \ MATERIAL:		TRATTAMENTO TERMICO \ HEAT TREATMENT:	NOTE \ NOTES:
ESEGUITO DA \ DRAWN BY: RIVIT	DATA:	TRATT. SUPERFICIALE \ SURF. TREATMENT:	Rugosità superficiale generale: General surface roughness:
CONTROLLATO DA \ CHECKED BY: RIVIT	DATA:	PROFONDITÀ TRATTAMENTO TERMICO (SURF) [mm]: HEAT TREATMENT (SURF) DEPTH [mm]:	NON SCALARE IL DISEGNO DO NOT RESIZE THE DRAW
APPROVATO DA \ APPROVED BY: RIVIT	DATA:	DUREZZA \ HARDNESS:	FUOGIO \ SHEET: 1 OF 1
		PESO \ WEIGHT:	FORMATO FOGGIO: A4
		Scale \ SCALE:	METODO 1 (ISO 128) METHOD 1 (ISO 128)
			REVISIONE: REVISION:
			CARTIGLIO \ FORMAT Mod.P023_07



**FASTENERS
& TOOLS**
RIVIT.IT