

ITEM TECHNICAL CARD

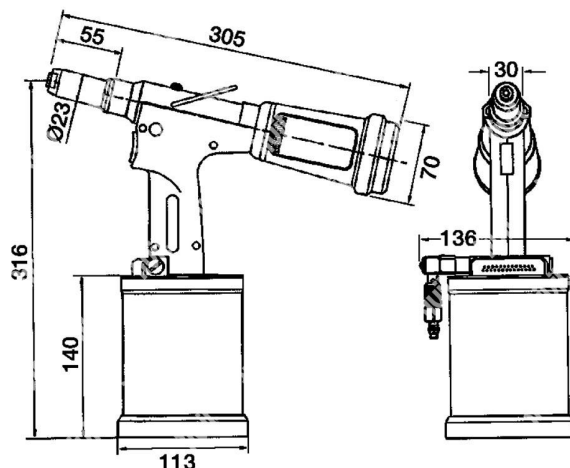

air consumption x cycle 6 bar (lt)	4,8
stroke (mm)	26
max power at 6bar (N)	16000
air working pressure (bar)	6
min/max air pressure (bar)	5 - 7
weight (kg)	1,866
noise level dB(A)	78,5
vibrations (m/s ²)	< 2,5

DESCRIZIONE \ DESCRIPTION: RIV504-Hydropneumatic tool for rivets up to d.6,4 (all materials) and		CATEGORIA \ CATEGORY: 4035800	
MATERIAL \ MATERIAL:		TRATTAMENTO TERMICO \ HEAT TREATMENT:	NOTE \ NOTES:
ESEGUITO DA \ DRAWN BY: RIVIT	DATA:	TRATT. SUPERFICIALE \ SURF. TREATMENT:	Rugosità superficiale generale: General surface roughness:
CONTROLLATO DA \ CHECKED BY: RIVIT	DATA:	PROFONDITÀ TRATTAMENTO TERMICO (SURF) [mm]: HEAT TREATMENT (SURF) DEPTH [mm]:	NON SCALARE IL DISEGNO DO NOT RESIZE THE DRAW
APPROVATO DA \ APPROVED BY: RIVIT	DATA:	DUREZZA \ HARDNESS:	METODO 1 (ISO 128) REVISIONE: METHOD 1 (ISO 128) REVISION:
		PESO \ WEIGHT:	Foglio \ SHEET: 1 OF 1 Scale \ SCALE: FORMATO FOGLIO: A4 SHEET FORMAT: CARTIGLIO \ FORMAT Mod.P023_07



**FASTENERS
& TOOLS**
RIVIT.IT