

ITEM TECHNICAL CARD

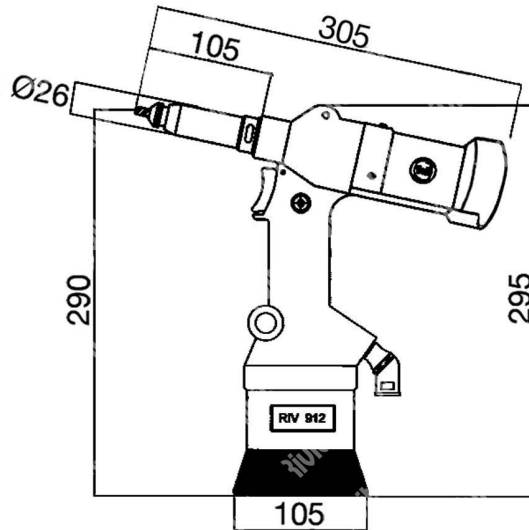

air consumption x cycle 6 bar (lt)	7,5
stroke (mm)	1/6,5
max power at 6bar (N)	22500
air working pressure (bar)	6
min/max air pressure (bar)	5 - 7
noise level dB(A)	78,5
vibrations (m/s ²)	< 2,5
motor speed (rpm)	2800
weight without kit (kg)	2,501

DESCRIZIONE \ DESCRIPTION: RIV912-Hydrop. tool for rivet nuts suppl in box without kit (kit available)		CATEGORIA \ CATEGORY: 3440900	
MATERIAL \ MATERIAL:		TRATTAMENTO TERMICO \ HEAT TREATMENT:	
NOTE \ NOTES:		Rugosità superficiale generale: General surface roughness:	
ESEGUITO DA \ DRAWN BY: RIVIT	DATA:	TRATT. SUPERFICIALE \ SURF. TREATMENT:	NON SCALARE IL DISEGNO DO NOT RESIZE THE DRAW
CONTROLLATO DA \ CHECKED BY: RIVIT	DATA:	PROFONDITÀ TRATTAMENTO TERMICO (SURF) [mm]: HEAT TREATMENT (SURF) DEPTH [mm]:	
APPROVATO DA \ APPROVED BY: RIVIT	DATA:	DUREZZA \ HARDNESS:	FUOGGIO \ SHEET: 1 OF 1
		PESO \ WEIGHT:	FORMATO FOGGIO: A4
		Scale \ SCALE:	METODO 1 (ISO 128) METHOD 1 (ISO 128)
			REVISIONE: REVISION:
			CARTIGLIO \ FORMAT Mod.P023_07



FASTENERS & TOOLS
RIVIT.IT