

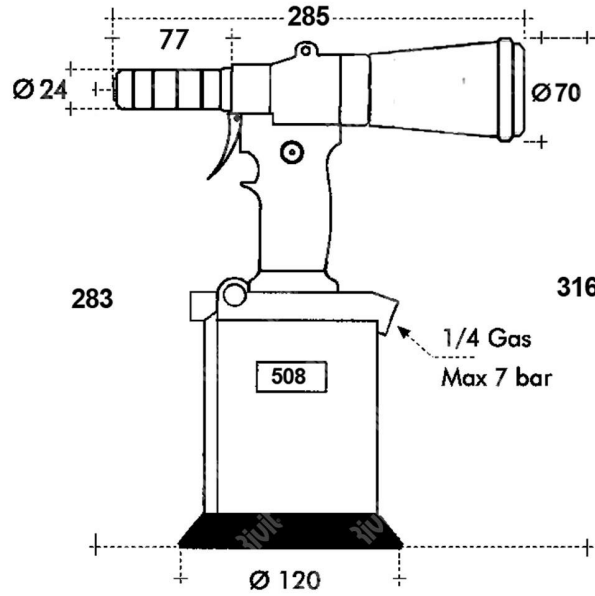

ITEM TECHNICAL CARD



DESCRIZIONE \ DESCRIPTION:				CATEGORIA \ CATEGORY:		3008000	
RIV508-Hydropneumatic tool in case without kit / (kit to be ordered)							
MATERIAL \ MATERIAL:		TRATTAMENTO TERMICO \ HEAT TREATMENT:		NOTE \ NOTES:			
ESEGUITO DA \ DRAWN BY:	DATA:	TRATT. SUPERFICIALE \ SURF. TREATMENT:		Rugosità superficiale generale: General surface roughness:			
CONTROLLATO DA \ CHECKED BY:	DATA:	PROFONDITÀ TRATTAMENTO TERMICO (SURF) [mm]: HEAT TREATMENT (SURF) DEPTH [mm]:		NON SCALARE IL DISEGNO DO NOT RESIZE THE DRAW			
APPROVATO DA \ APPROVED BY:	DATA:	DUREZZA \ HARDNESS:	FOGLIO \ SHEET:	FORMATO FOGLIO: SHEET FORMAT:	METODO 1 (ISO 128) METHOD 1 (ISO 128)	REVISIONE: REVISION:	FASTENERS & TOOLS  RIVIT.IT
		PESO \ WEIGHT:	Scale \ SCALE:	CARTIGLIO \ FORMAT Mod.P023_07	