

ITEM TECHNICAL CARD

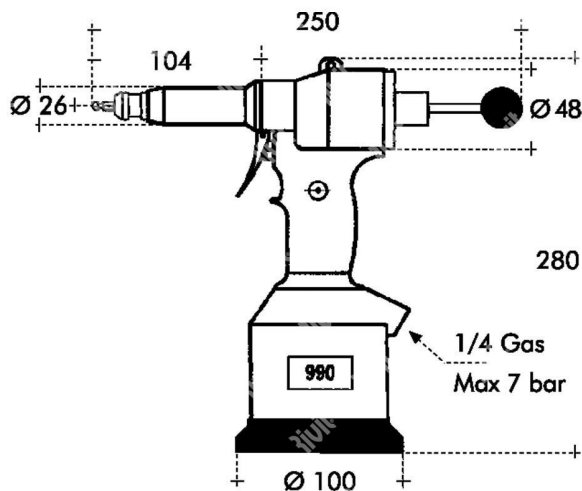

air consumption x cycle 6 bar (lt)	2,5
stroke (mm)	6
max power at 6bar (N)	19000
air working pressure (bar)	6
min/max air pressure (bar)	5 - 7
noise level dB(A)	< 80
vibrations (m/s ²)	< 2,5
weight without kit (kg)	2,133

DESCRIZIONE \ DESCRIPTION: RIV990- Hydrop. hexcutter tool in a box without ki (kit on request		CATEGORIA \ CATEGORY: 2986300	
MATERIAL \ MATERIAL:		TRATTAMENTO TERMICO \ HEAT TREATMENT:	NOTE \ NOTES:
ESEGUITO DA \ DRAWN BY: RIVIT	DATA:	TRATT. SUPERFICIALE \ SURF. TREATMENT:	Rugosità superficiale generale: General surface roughness:
CONTROLLATO DA \ CHECKED BY: RIVIT	DATA:	PROFONDITÀ TRATTAMENTO TERMICO (SURF) [mm]: HEAT TREATMENT (SURF) DEPTH [mm]:	NON SCALARE IL DISEGNO DO NOT RESIZE THE DRAW
APPROVATO DA \ APPROVED BY: RIVIT	DATA:	DUREZZA \ HARDNESS:	METODO 1 (ISO 128) REVISIONE: METHOD 1 (ISO 128) REVISION:
		PESO \ WEIGHT:	CARTIGLIO \ FORMAT Mod.P023_07
		FOGLIO \ SHEET: 1 OF 1	FORMATO FOGLIO: SHEET FORMAT: A4
		Scale \ SCALE:	



**FASTENERS
& TOOLS**
RIVIT.IT