

ITEM TECHNICAL CARD

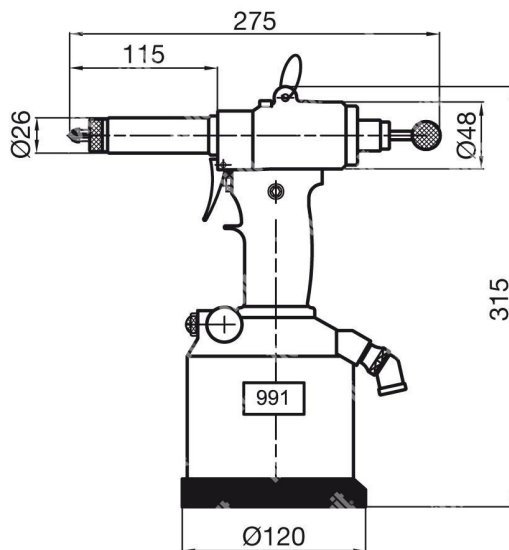

Luftverbrauch pro Zyklus bei 6 bar (lt)	2,5
Hub (mm)	12
Zugkraft bei 6bar (N)	21000
Arbeitsluftdruck (bar)	6
Luftdruck min-max (bar)	5 - 7
Geräuschpegel dB(A)	< 80
Vibrationen (m/s ²)	< 2,5
Gewicht ohne kit (kg)	2,400

DESCRIZIONE \ DESCRIPTION: RIV991-Hydrop. hexcutter tool in a box without kit (kit on request		CATEGORIA \ CATEGORY:		4630400	
MATERIAL \ MATERIAL:		TRATTAMENTO TERMICO \ HEAT TREATMENT:		NOTE \ NOTES:	
ESEGUITO DA \ DRAWN BY: RIVIT	DATA:	TRATT. SUPERFICIALE \ SURF. TREATMENT:	Rugosità superficiale generale: General surface roughness:	NON SCALARE IL DISEGNO DO NOT RESIZE THE DRAW	
CONTROLLATO DA \ CHECKED BY: RIVIT	DATA:	PROFONDITÀ TRATTAMENTO TERMICO (SURF) [mm]: HEAT TREATMENT (SURF) DEPTH [mm]:			
APPROVATO DA \ APPROVED BY: RIVIT	DATA:	DUREZZA \ HARDNESS:	FOGLIO \ SHEET: 1 OF 1	FORMATO FOGLIO: SHEET FORMAT: A4	METODO 1 (ISO 128) METHOD 1 (ISO 128)
		PESO \ WEIGHT:	Scale \ SCALE:	CARTIGLIO \ FORMAT Mod.P023_07	REVISIONE: REVISION:



**FASTENERS
& TOOLS**
RIVIT.IT