

ITEM TECHNICAL CARD

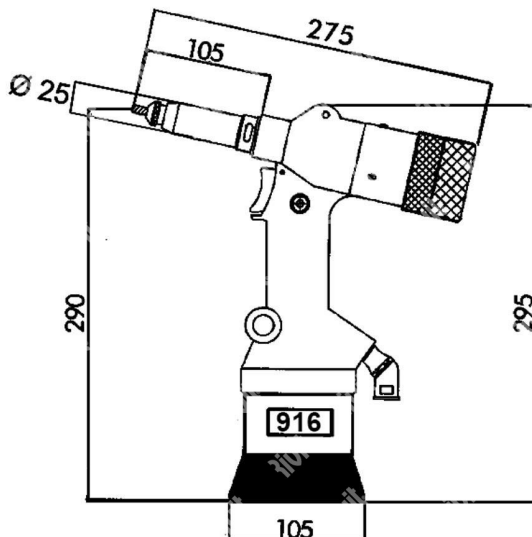

Luftverbrauch pro Zyklus bei 6 bar (lt)	7,5
Hub (mm)	16
Zugkraft bei 6bar (N)	13000
Arbeitsluftdruck (bar)	6
Luftdruck min-max (bar)	5 - 7
Geräuschpegel dB(A)	78,5
Vibrationen (m/s <sup>2</sup> )	< 2,5
Gewicht ohne kit (kg)	2,558

DESCRIZIONE \ DESCRIPTION: <b>RIV916-Hydropneumatic tool for Tubriv and Jackriv (in PVC case)</b>		CATEGORIA \ CATEGORY: <b>4154500</b>	
MATERIAL \ MATERIAL:		TRATTAMENTO TERMICO \ HEAT TREATMENT:	NOTE \ NOTES:
ESEGUITO DA \ DRAWN BY: <b>RIVIT</b>	DATA:	TRATT. SUPERFICIALE \ SURF. TREATMENT:	Rugosità superficiale generale: General surface roughness:
CONTROLLATO DA \ CHECKED BY: <b>RIVIT</b>	DATA:	PROFONDITÀ TRATTAMENTO TERMICO (SURF) [mm]: HEAT TREATMENT (SURF) DEPTH [mm]:	<b>NON SCALARE IL DISEGNO DO NOT RESIZE THE DRAW</b>
APPROVATO DA \ APPROVED BY: <b>RIVIT</b>	DATA:	DUREZZA \ HARDNESS:	FUOGIO \ SHEET: <b>1 OF 1</b>
		PESO \ WEIGHT:	FORMATO FOGGIO: <b>A4</b>
		Scale \ SCALE:	METODO 1 (ISO 128) REVISIONE: METHOD 1 (ISO 128) REVISION:
			CARTIGLIO \ FORMAT <b>Mod.P023_07</b>



**FASTENERS  
& TOOLS**  
RIVIT.IT