

ITEM TECHNICAL CARD

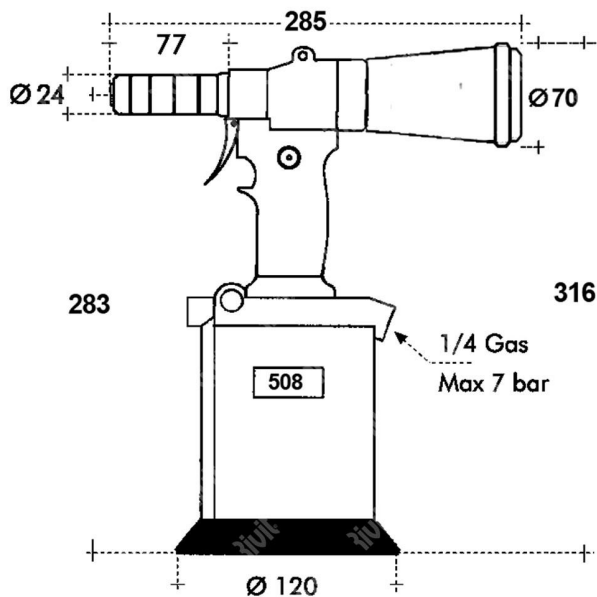

Luftverbrauch pro Zyklus bei 6 bar (lt)	4,9
Hub (mm)	21
Zugkraft bei 6bar (N)	21000
Arbeitsluftdruck (bar)	6
Luftdruck min-max (bar)	5 - 7
Geräuschpegel dB(A)	78,5
Vibrationen (m/s ²)	< 2,5
Gewicht ohne kit (kg)	2,350

DESCRIZIONE \ DESCRIPTION: RIV508-Hydropneumatic tool in case without kit (kit to be ordered)		CATEGORIA \ CATEGORY: 3008000	
MATERIAL \ MATERIAL:		TRATTAMENTO TERMICO \ HEAT TREATMENT:	
ESEGUITO DA \ DRAWN BY: RIVIT		NOTE \ NOTES:	
DATA:		TRATT. SUPERFICIALE \ SURF. TREATMENT:	
CONTROLLATO DA \ CHECKED BY: RIVIT		Rugosità superficiale generale: General surface roughness:	
DATA:		PROFONDITÀ TRATTAMENTO TERMICO (SURF) [mm]: HEAT TREATMENT (SURF) DEPTH [mm]:	
APPROVATO DA \ APPROVED BY: RIVIT		NON SCALARE IL DISEGNO DO NOT RESIZE THE DRAW	
DATA:		DUREZZA \ HARDNESS:	
		FOGLIO \ SHEET: 1 OF 1	
		FORMATO FOGLIO: A4	
		SHEET FORMAT: A4	
		METODO 1 (ISO 128) REVISIONE: METHOD 1 (ISO 128) REVISION:	
		PESO \ WEIGHT:	
		Scale \ SCALE:	
		CARTIGLIO \ FORMAT Mod.P023_07	



FASTENERS & TOOLS
RIVIT.IT